



**Modular Cooking Range Line  
900XP 1200mm Gas Fry Top HP, Smooth  
scratch resistant chromium Plate**

ITEM # \_\_\_\_\_

MODEL # \_\_\_\_\_

NAME # \_\_\_\_\_

SIS # \_\_\_\_\_

AIA # \_\_\_\_\_

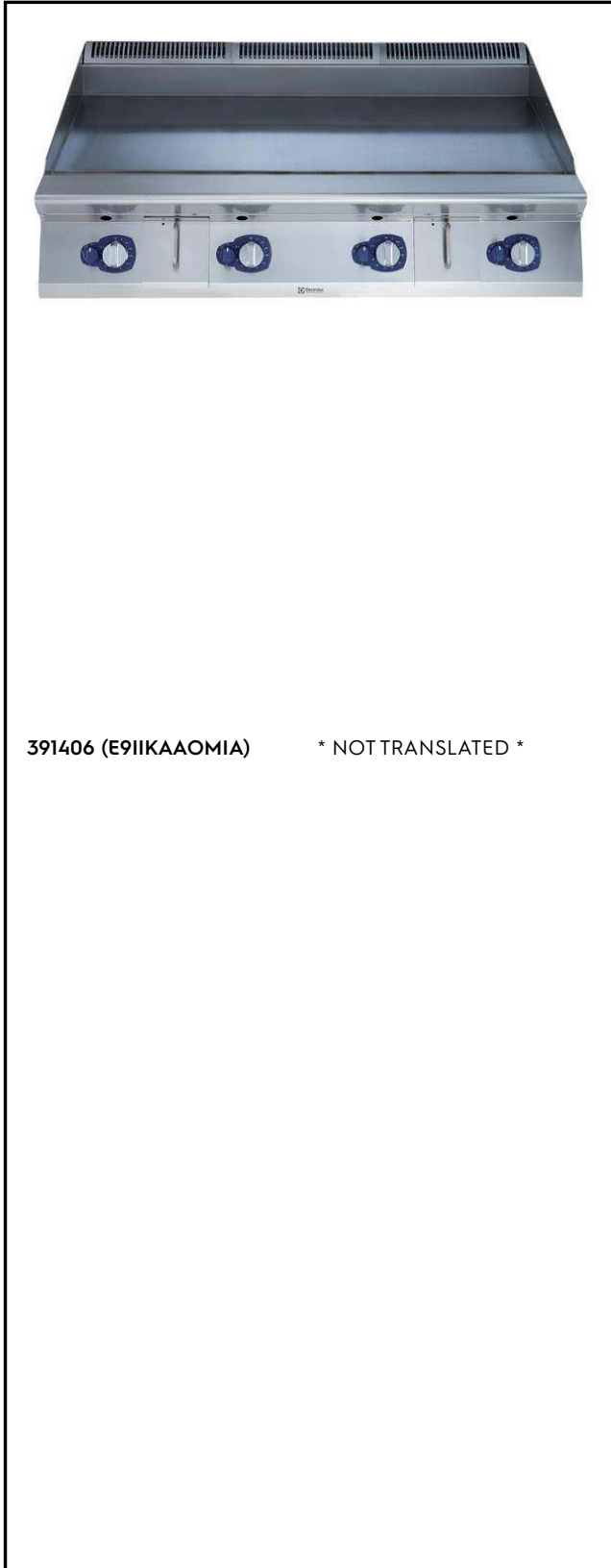

391406 (E911KAAOMIA) \* NOT TRANSLATED \*

### Main Features

- Exclusive IcyHot installation: combine the Fry Top HP with the dual temperature refrigerated/freezer base HP and obtain a single appliance which simultaneously increases productivity and facilitates cooking and storage operations.
- Unit to be mounted on open base cupboards, bridging supports or cantilever systems.
- Two large drain holes on cooking surface permits the draining of fat into two separate 3 liter collectors placed under the cooking surface.
- Stainless steel high splash guards on the rear and sides of cooking surface.
- Piezo spark ignition with thermostatic valve for added safety.
- The special design of the control knob system guarantees against water infiltration.
- IPX5 water protection.
- Units have 4 independent controls to regulate temperature of the cooking surface.
- Scratch resistant cooking surface thanks to a special treatment of the chromium plate.
- Easy to clean and corrosion resistant chromium surface.
- Temperature range from 90° up to 270°C.
- Suitable for countertop installation.

### Construction

- Unit is 930 mm deep to give a larger working surface area.
- All exterior panels in Stainless Steel with Scotch Brite finishing.
- AISI 304 stainless steel worktop, 2mm thick.
- Model has right-angled side edges to allow flush fitting joints between units, eliminating gaps and possible dirt traps.
- Non-scratch cooking surface 20mm thick for optimum grilling results and ease of use.
- Cooking surface completely smooth.

### Included Accessories

- 1 of Scraper for smooth plate fry tops PNC 164255

### Optional Accessories

- Scraper for smooth plate fry tops PNC 164255
- Support for bridge type system, 1200mm PNC 206139
- Support for bridge type system, 1400mm PNC 206140
- Support for bridge type system, 1600mm PNC 206141
- BACK HANDRAIL 1200 MM - MARINE PNC 206309
- Water drain for fry tops HP PNC 206345
- SCRAPER FOR RIBB PLATE FRY TOP PNC 206420
- - NOT TRANSLATED - PNC 206455
- - NOT TRANSLATED - PNC 206468

APPROVAL: \_\_\_\_\_





**Electrolux**  
PROFESSIONAL

**Modular Cooking Range Line  
900XP 1200mm Gas Fry Top HP, Smooth  
scratch resistant chromium Plate**

- Frontal handrail 1200mm PNC 216049
- Frontal handrail 1600mm PNC 216050
- Pressure regulator for gas units PNC 927225

**Recommended Detergents**

- \*NOT TRANSLATED\* PNC 0S2292



**Modular Cooking Range Line  
900XP 1200mm Gas Fry Top HP, Smooth scratch resistant chromium  
Plate**  
The company reserves the right to make modifications to the products  
without prior notice. All information correct at time of printing.

2026.04.13

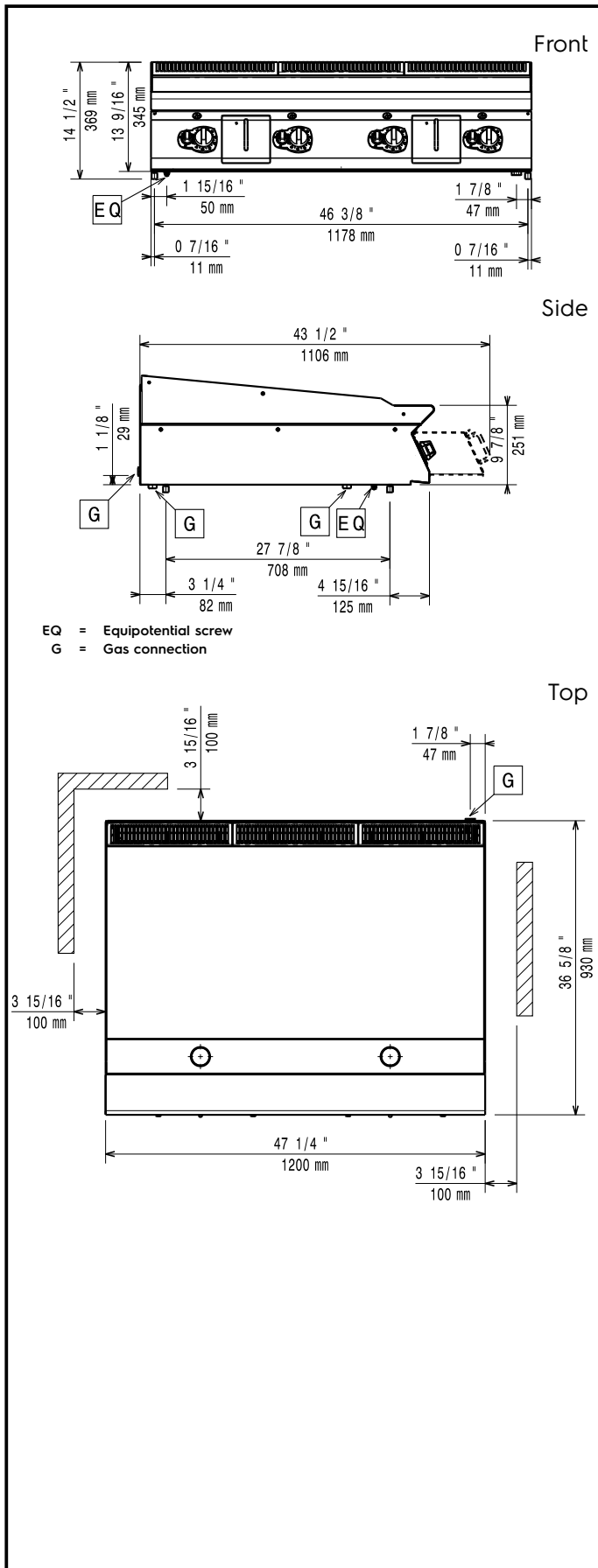

### Gas

<b>Gas Power:</b>	33 kW
<b>Standard gas delivery:</b>	Natural Gas G20 (20mbar)
<b>Gas Type Option:</b>	LPG; Natural Gas
<b>Gas Inlet:</b>	1/2"

### Key Information:

<b>External dimensions, Width:</b>	1200 mm
<b>External dimensions, Depth:</b>	930 mm
<b>External dimensions, Height:</b>	250 mm
<b>Net weight:</b>	150 kg
<b>Shipping weight:</b>	199 kg
<b>Shipping height:</b>	580 mm
<b>Shipping width:</b>	1020 mm
<b>Shipping depth:</b>	1270 mm
<b>Shipping volume:</b>	0.75 m <sup>3</sup>
<b>Cooking surface width:</b>	1194 mm
<b>Cooking surface depth:</b>	610 mm

If appliance is set up or next to or against temperature sensitive furniture or similar, a safety gap of approximately 150 mm should be maintained or some form of heat insulation fitted.